

# Additif

Français

## 1 Kit d'intégration en toiture

 Agrandir la découpe de la tôle de recouvrement supérieure (droite ou gauche) pour le passage des flexibles hydrauliques.

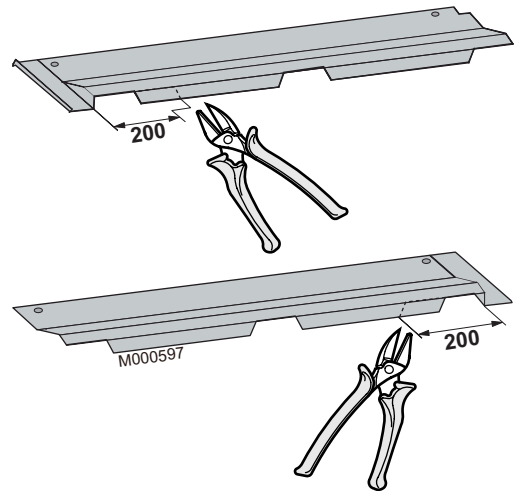

## 2 EG 419 : Habillage pour un montage en intégration de toiture

### 2.1 Vue d'ensemble

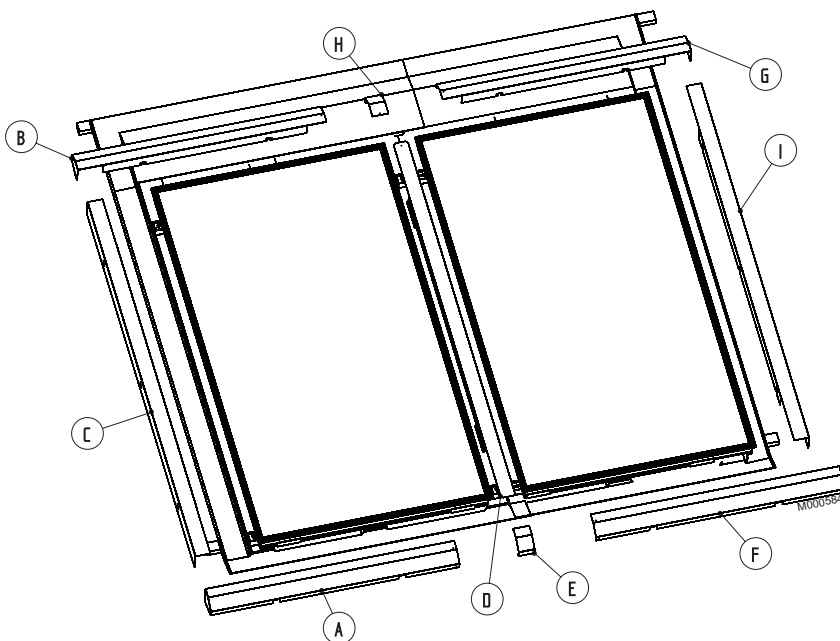

- A Carter horizontal n° 1
- B Carter horizontal n° 2
- C Carter latéral
- D Tôle de jonction
- E Pièce de recouvrement inférieur de la tôle de jonction
- F Carter horizontal n° 2
- G Carter horizontal n° 1
- H Pièce de recouvrement supérieur de la tôle de jonction
- I Carter latéral



**Attention :**

Mettre en place la **tôle de jonction (repère D)** avant de fixer le 2e capteur solaire sur les rails de montage **et** avant d'effectuer le raccordement entre les deux capteurs solaires.



## 2.2 Montage de l'habillage

1. Introduire la tôle de jonction dans la rainure du premier capteur solaire.
2. Faire glisser le 2e capteur solaire vers le premier et emboîter la tôle de jonction dans sa rainure.

**⚠ Veiller au bon alignement des raccords. Guider avec précaution le capteur dans les raccords bicones.**

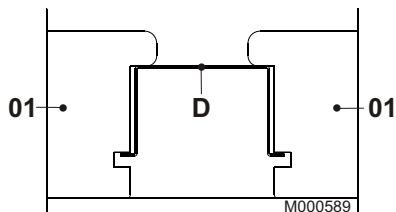

**01** Capteur solaire  
**D** Tôle de jonction

3. Fixer les pattes de fixation.
4. Serrer les écrous des raccords bicones.

**⚠ Veiller à bien maintenir les raccords bicones pendant la fixation pour ne pas endommager les raccords du capteur.**

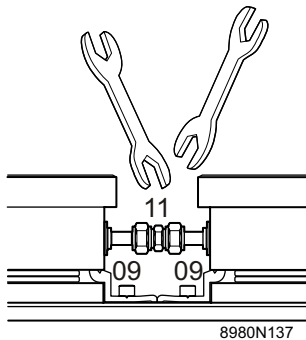

**i** Le jeu vertical de la tôle de jonction permet d'accéder aux raccords hydrauliques et de fixer les capteurs solaires.



5. Insérer les écrous à billes dans les rainures des capteurs solaires suivant les cotes ci-après.

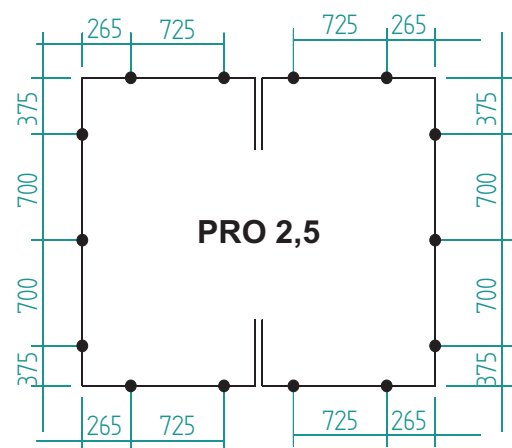
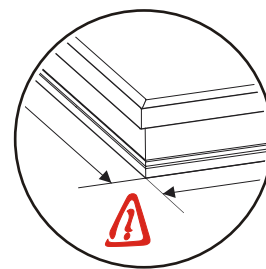

6. Positionner les vis dans les écrous à billes. Visser de 2 tours.



M000586

7. Mettre en place le carter horizontal inférieur en emboîtant les encoches dans les vis.

**⚠ S'assurer de la bonne mise en place du carter sous le rebord du capteur solaire.**



M000587

8. Resserrer les vis pour maintenir le carter en place. Ne pas bloquer afin d'ajuster la position du carter à la fin du montage.



M000588

9. Procéder de la même manière pour les éléments suivants :

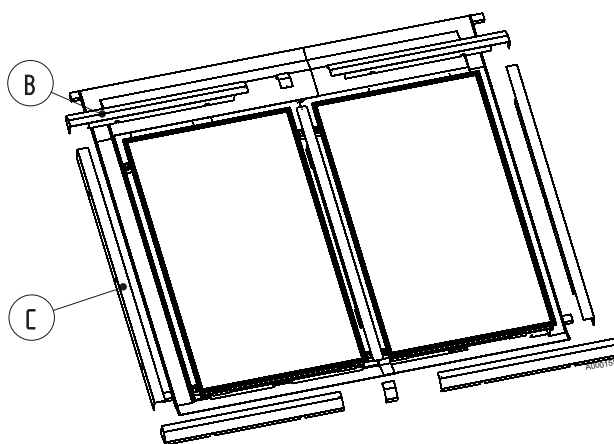

- Carter horizontal supérieur (B)
- Carter latéral (C)

10. Emboîter la pièce de recouvrement inférieur sur le carter horizontal en la faisant glisser.

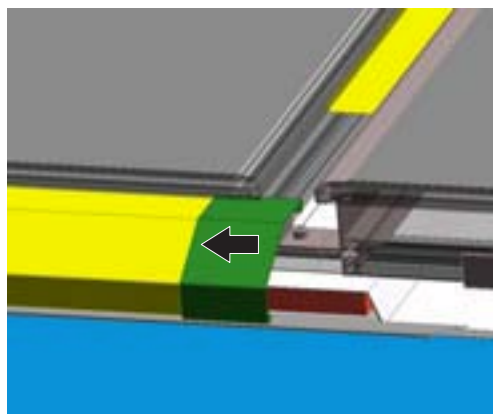

M000591

11. Monter les pièces suivantes en procédant comme pour les pièces A - B - C :

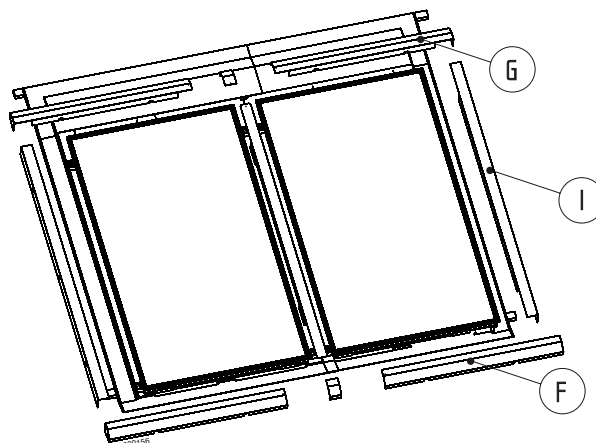

- Carter horizontal inférieur (F)
- Carter horizontal supérieur (G)
- Carter latéral (I)

12. Mettre en place la pièce de recouvrement supérieur (H).

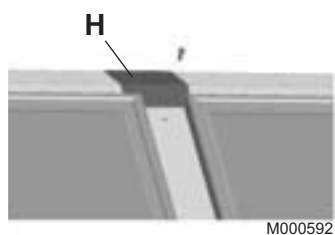

13. Fixer la tôle de jonction à la pièce de recouvrement supérieur à l'aide d'une vis à tôle.

14. Ajuster l'habillage des capteurs solaires de façon à ne laisser aucun jour entre les pièces.

15. Serrer toutes les vis à tête cylindrique.

 **Veiller à la bonne position des vis dans les trous oblongs.**

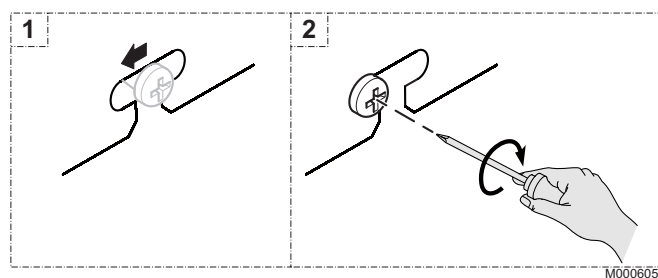

# Zusatzblatt

Deutsch

## 1 Indach-Montageset

 Den Ausschnitt im oberen Eindeckblech (rechts oder links) für die Durchführung der Hydraulikschläuche vergrößern.

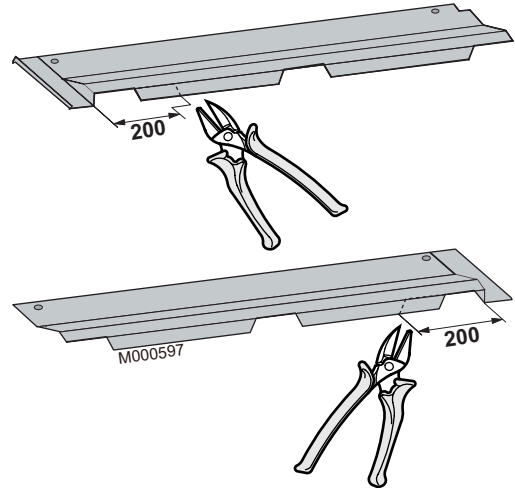

## 2 EG 419: Verkleidung für Indach-Montage

### 2.1 Übersicht

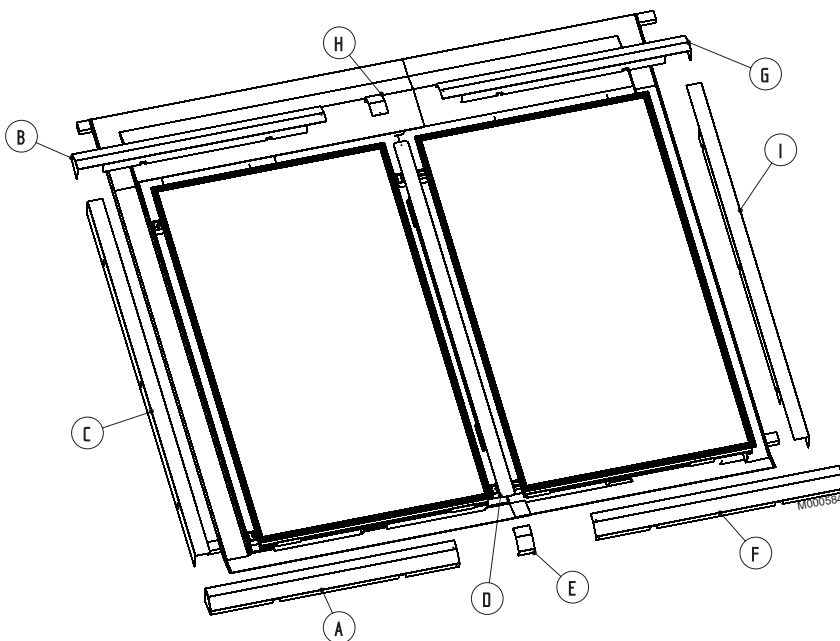

- A Horizontaler Rahmen Nr. 1
- B Horizontaler Rahmen Nr. 2
- C Seitlicher Rahmen
- D Übergangsblech
- E Unteres Abdeckteil des Übergangsblechs
- F Horizontaler Rahmen Nr. 2
- G Horizontaler Rahmen Nr. 1
- H Oberes Abdeckteil des Übergangsblechs
- I Seitlicher Rahmen

 **Achtung:**

Das Verbindungsblech (D) einsetzen, bevor der zweite Sonnenkollektor auf den Montageschienen befestigt wird und die beiden Sonnenkollektoren verbunden werden.



## 2.2 Montage der Verkleidung

1. Übergangsblech in die Nut des ersten Sonnenkollektors einsetzen.
2. Zweiten Sonnenkollektor in Richtung des ersten schieben und Übergangsblech in die Nut des zweiten Kollektors einsetzen.

**!** Auf die Flucht der Anschlussstutzen achten. Kollektor vorsichtig in die Klemmringverschraubungen einführen.

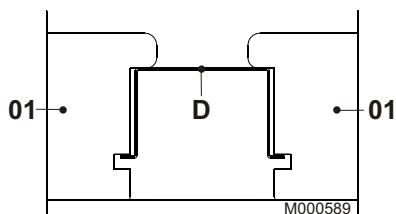

- 01 Solarkollektor
- D Übergangsblech

3. Befestigungsbügel fixieren.
4. Die Muttern der Klemmringverschraubungen festziehen.

**!** Beim Festziehen der Klemmringverschraubungen gegenhalten, da sonst die Verrohrung des Kollektors beschädigt werden kann.

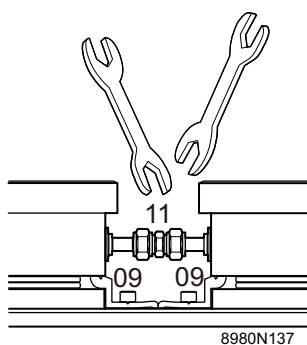

**i** Das vertikale Spiel des Übergangsblechs ermöglicht den Zugang zu den Hydraulikanschlüssen und das Anbringen der Sonnenkollektoren.



5. Die Spindelmuttern gemäß den folgenden Maßen in die Nuten der Sonnenkollektoren einsetzen.

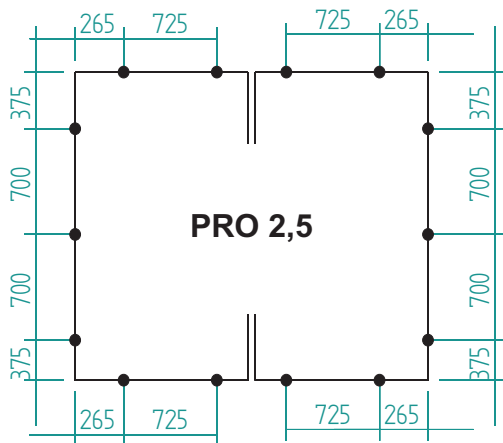
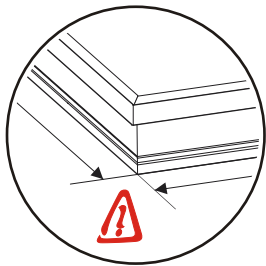
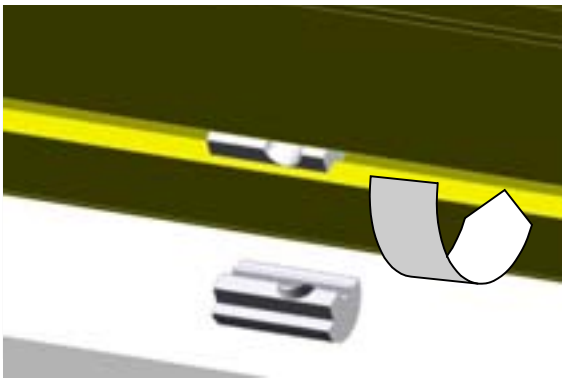

M000983

6. Schrauben in die Spindelmuttern einsetzen. Um 2 Umdrehungen festziehen.



M000586

7. Das untere horizontale Gehäuse einsetzen. Dabei die Aussparungen in die Schrauben einhaken.

- !** Sicherstellen, dass das Gehäuse ordnungsgemäß unter dem Rand des Sonnenkollektors platziert ist.



M000587

8. Die Schrauben anziehen, um das Gehäuse zu fixieren. Nicht vollständig festziehen, um die Position des Gehäuses nach Abschluss der Montage anpassen zu können.



M000588

9. Dieselben Schritte für die weiteren Elemente ausführen:

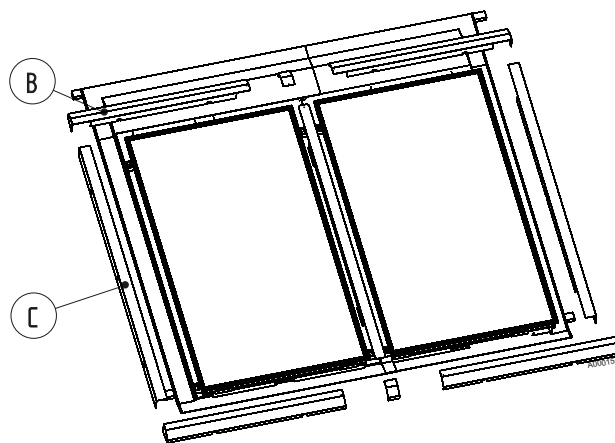

- Oberes horizontales Gehäuse (B)
- Seitlicher Rahmen (C)

10. Das untere Abdeckteil auf das horizontale Gehäuse schieben.

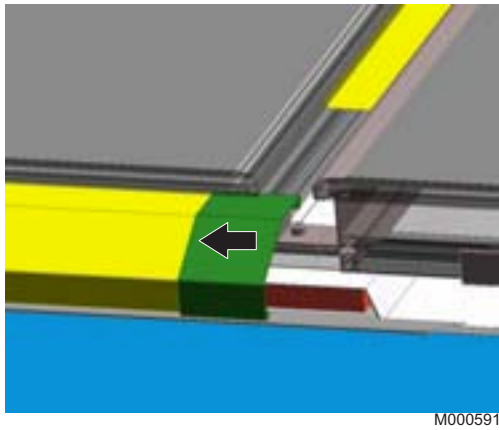

11. Die folgenden Teile mit demselben Verfahren wie für die Schritte **A - B - C** montieren:

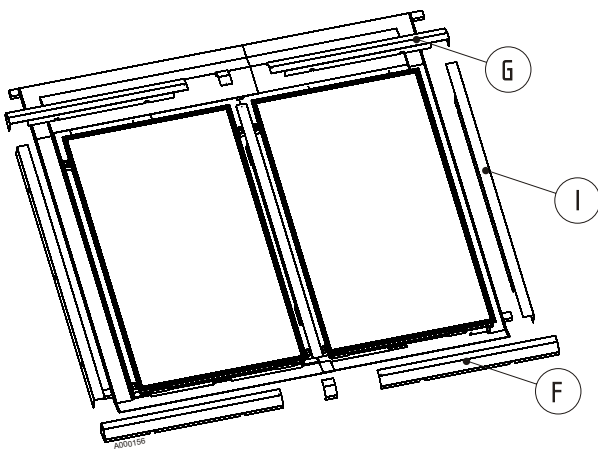

- Unteres horizontales Gehäuse (F)
- Oberes horizontales Gehäuse (G)
- Seitlicher Rahmen (I)

12. Oberes Abdeckteil montieren (H).

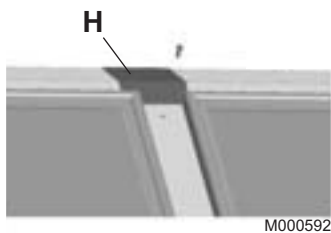

13. Verbindungsblech mit einer Blechschraube am oberen Abdeckteil fixieren.

14. Verkleidung der Sonnenkollektoren so anpassen, dass zwischen den Teilen kein Spalt verbleibt.

15. Alle Zylinderschrauben festziehen.

**!** Darauf achten, dass die Schrauben in den länglichen Aussparungen richtig sitzen.

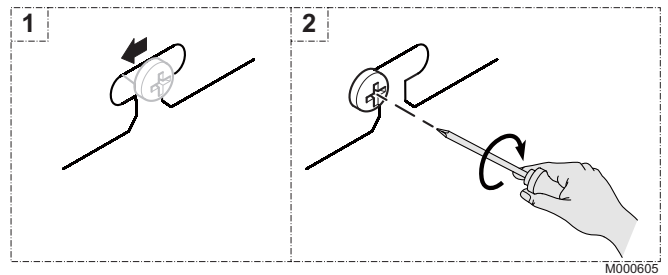



# Bijkomend blad

Nederlands

## 1 Set voor inbouw in dakbedekking

 Vergroot de afsnijding van de bovenste afdekplaat (rechts of links) voor het doorvoeren van de hydraulische slangen.

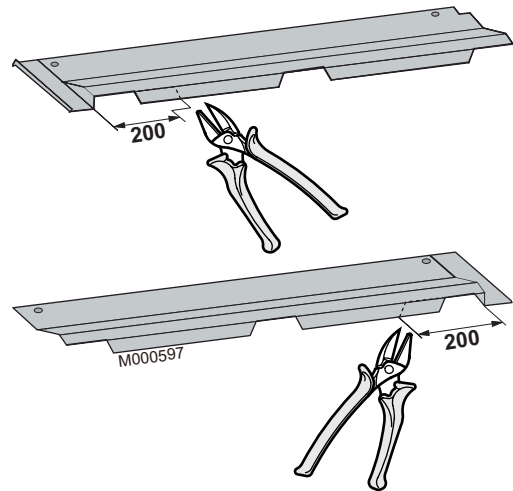

## 2 EG 419: Voering voor inbouwmontage in dakbedekking

### 2.1 Overzicht

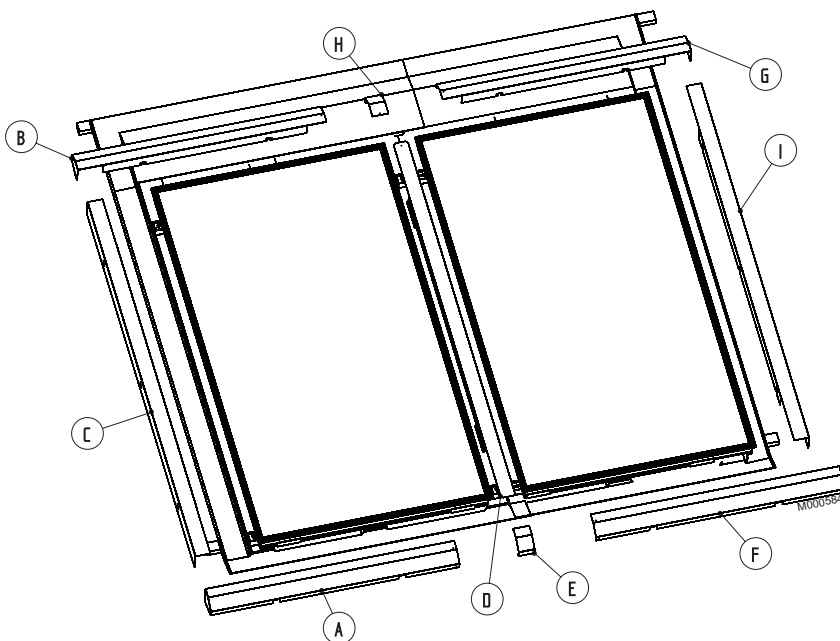

- A Horizontale carter nr. 1
- B Horizontale carter nr. 2
- C Zijcarter
- D Aansluitplaat
- E Onderste afdekelement van de aansluitplaat
- F Horizontale carter nr. 2
- G Horizontale carter nr. 1
- H Bovenste afdekelement van de aansluitplaat
- I Zijcarter



**Opgelet:**

Zet de **aansluitplaat (nummer D)** op zijn plaats alvorens de 2e zonnecollector op de montagerails te bevestigen **et** alvorens de twee zonnecollectoren op elkaar aan te sluiten.



## 2.2 Montage van de bekleding

1. Steek de aansluitplaat in de groef van de eerste zonnecollector.
2. Schuif de 2e zonnecollector naar de eerste en steek de afsluitplaat in zijn groef.

 **Let op het in lijn liggen van de wartels. Geleid het zonnepaneel voorzichtig in de biconische wartels.**

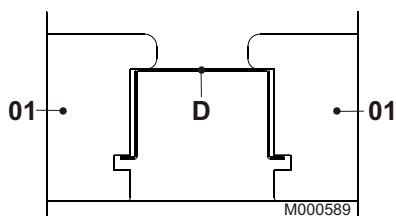

- 01 Zonnepaneel
- D Aansluitplaat

3. Bevestig de bevestigingslipjes.
4. Zet de moeren van de biconische wartels vast.

 **Houd de biconische wartels bij het vastzetten tegen, zodat de wartels van het zonnepaneel niet beschadigen.**

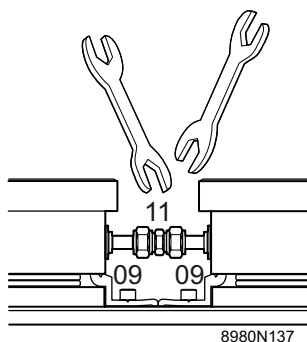

 Door de verticale speling van de aansluitplaat heeft men toegang tot de hydraulische aansluitingen en kunnen de zonnecollectoren bevestigd worden.



5. Steek de kogelmoeren in de groeven van de zonnecollectoren volgens de hierna gegeven maten.

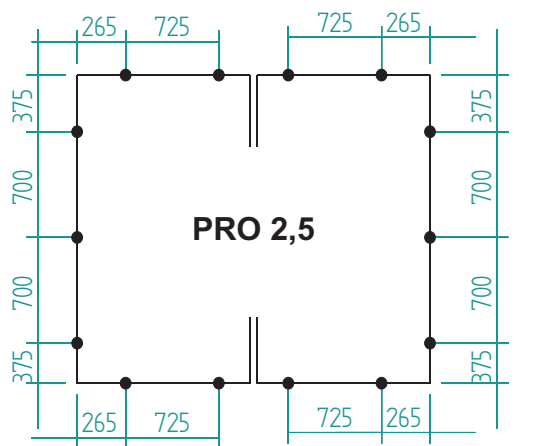
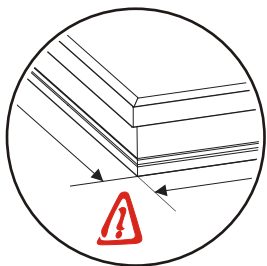

M000983

6. Plaats de schroeven in de kogelmoeren. Draai ze 2 slagen vast.



M000586

7. Plaats het onderste horizontale carter door de inkepingen in de schroeven te steken.

- !** Controleer of het carter goed onder de rand van de zonnecollector geplaatst is.



M000587

8. Draai de schroeven weer vast op het carter op zijn plaats te houden. Niet borgen om de positie van het carter aan het einde van de montage aan te kunnen passen.

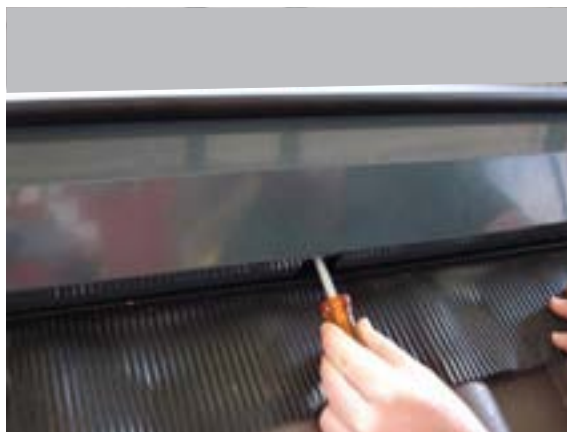

M000588

9. Ga op dezelfde wijze te werk voor de volgende elementen:

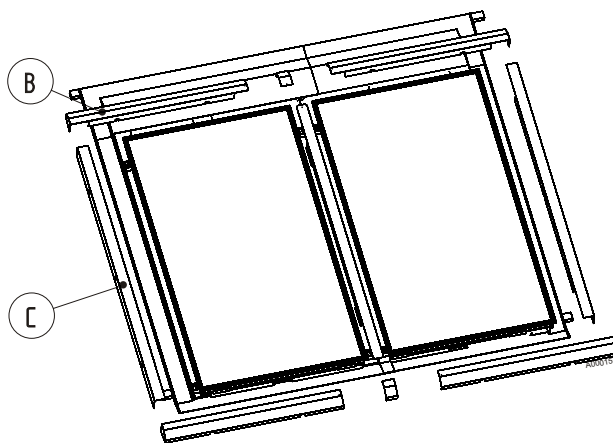

- Bovenste horizontale carter (B)
- Zijcarter (C)

10. Plaats het onderste afdekelement op het horizontale carter en schuif het op zijn plaats.

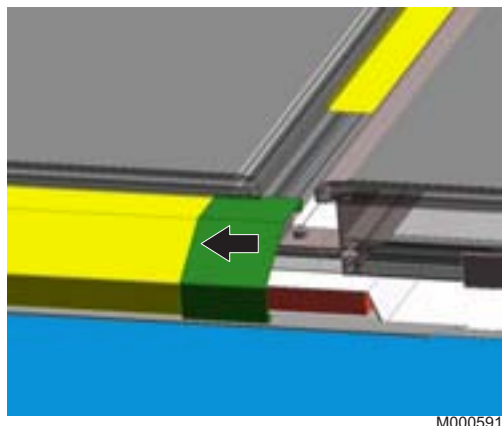

11. Monteer de volgende elementen op dezelfde wijze als de elementen **A - B - C**:

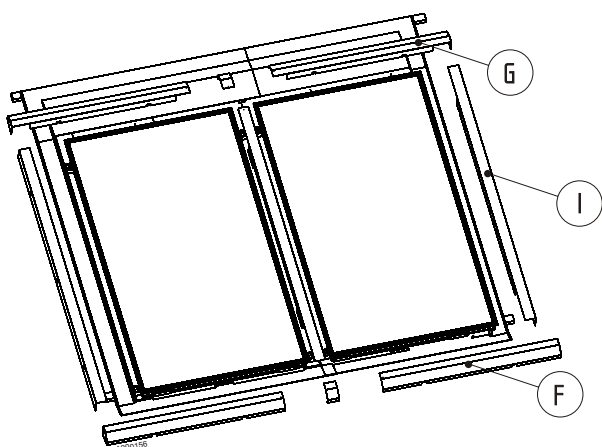

- Onderste horizontale carter (**F**)
- Bovenste horizontale carter (**G**)
- Zijcarter (**I**)

12. Zet het bovenste afdekelement op zijn plaats (**H**).

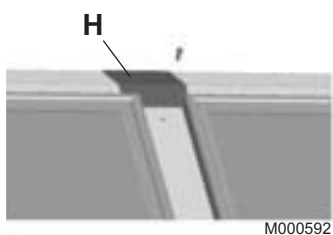

13. Bevestig de aansluitplaat op het bovenste afdekelement met behulp van een plaatschroef.

14. Pas de voering van de zonnecollectoren zodanig aan dat er geen licht tussen de elementen door kan schijnen.

15. Draai alle schroeven met cilinderkop aan.

 **Zorg dat de schroeven goed in de langwerpige gaten geplaatst zijn.**

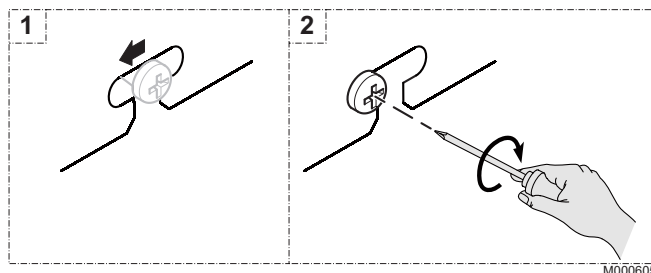

# Addendum

English

## 1 Roof integration kit

 Enlarge the cut-out in the upper covering plate (right or left) to make room for the hydraulic hoses.

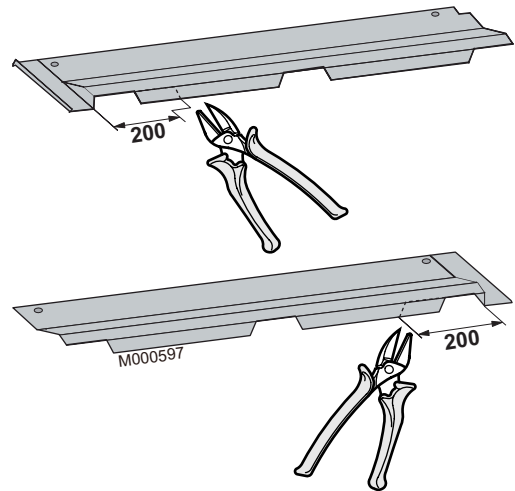

## 2 EG 419: Cladding for assembly integrated into the roof

### 2.1 Overview

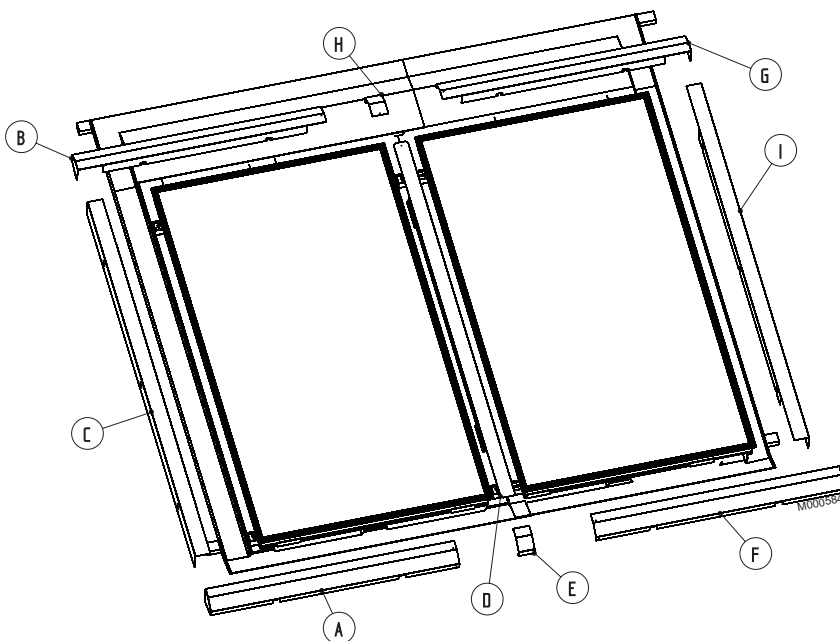

- A Horizontal housing no. 1
- B Horizontal housing no. 2
- C Lateral housing
- D Junction plate
- E Part for covering the lower section of the junction plate
- F Horizontal housing no. 2
- G Horizontal housing no. 1
- H Part for covering the upper section of the junction plate
- I Lateral housing



**Warning:**

Put the **junction plate (ref. D)** in place before securing the second solar collector to the assembly rails **and** before making the connection between the two solar collectors.



## 2.2 Casing assembly

1. Feed the junction plate into the groove on the first solar collector.
2. Slide the second solar collector towards the first and engage the junction plate in its groove.

**!** Make sure the connections pipes are aligned. Slide the connections on the second solar panel into the clamping ring fitting carefully.

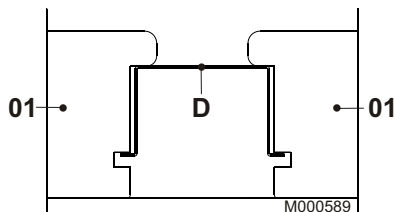

- 01 Solar collector
- D Junction plate

3. Secure the fastening lugs.
4. Tighten the nuts on the clamping ring fittings.

**!** When tightening the clamping ring fittings, use a second spanner to prevent the centre part of the fitting from turning, as otherwise the solar-panel pipes may be damaged.

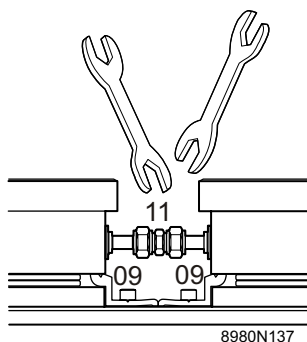

**i** The vertical play in the junction plate allows access to the hydraulic connections and makes it possible to secure the solar collectors.

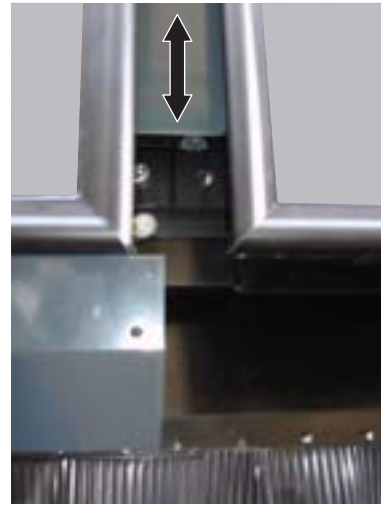

5. Insert the ball nuts into the grooves in the solar collectors in accordance with the following dimensions.

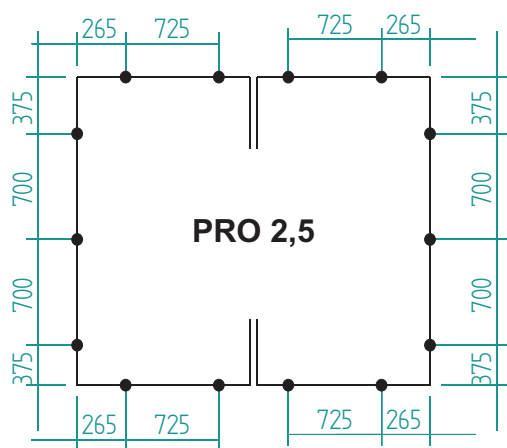
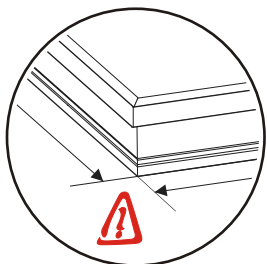

M000983

6. Position the screws in the ball nuts. Tighten by 2 turns.



M000586

7. Put the lower horizontal housing in place by interlocking the notches in the screws.

8. **!** Ensure that the housing is in the correct position under the edge of the solar collector.



M000587

8. Tighten the screws to hold the housing in place. Do not block in order to adjust the position of the housing at the end of assembly.



M000588

9. Proceed in the same way for the following elements:

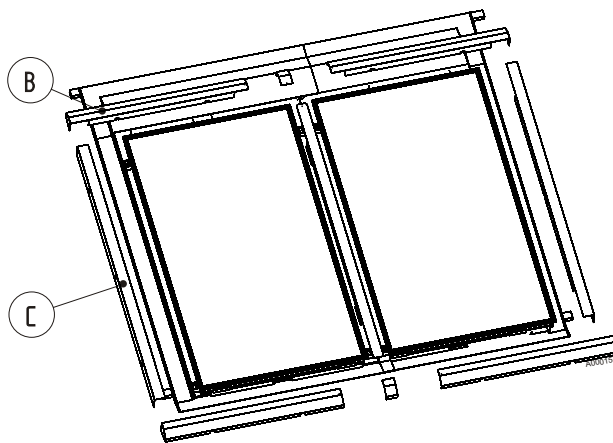

- Upper horizontal housing (B)
- Lateral housing (C)

10. Interlock the lower covering part with the horizontal housing by sliding it into position.

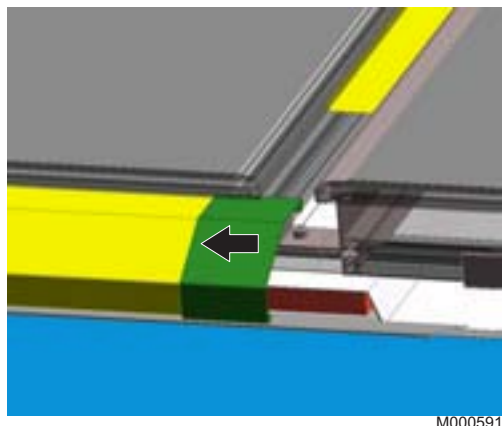

15. Tighten all the cheese head screws.

 Ensure that the screws are correctly positioned in the oblong holes.

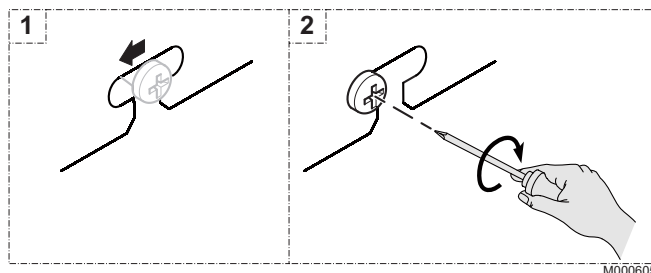

11. Fit the following parts by proceeding as you did for parts **A - B - C**:

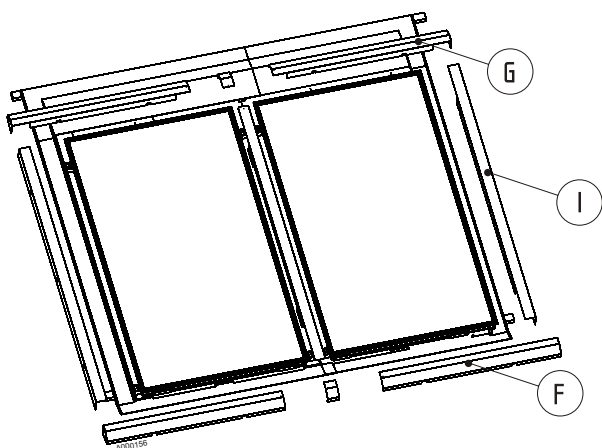

- Lower horizontal housing (F)
- Upper horizontal housing (G)
- Lateral housing (I)

12. Put the upper covering part in place (H).

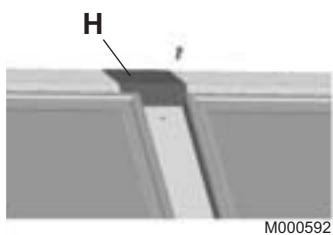

13. Secure the junction plate to the upper covering part using a self-tapping screw.

14. Adjust the cladding of the solar collectors in such a way as to leave no gaps between the parts.